

## Schweizer Railway Carrier for MERROW Sewing Machines

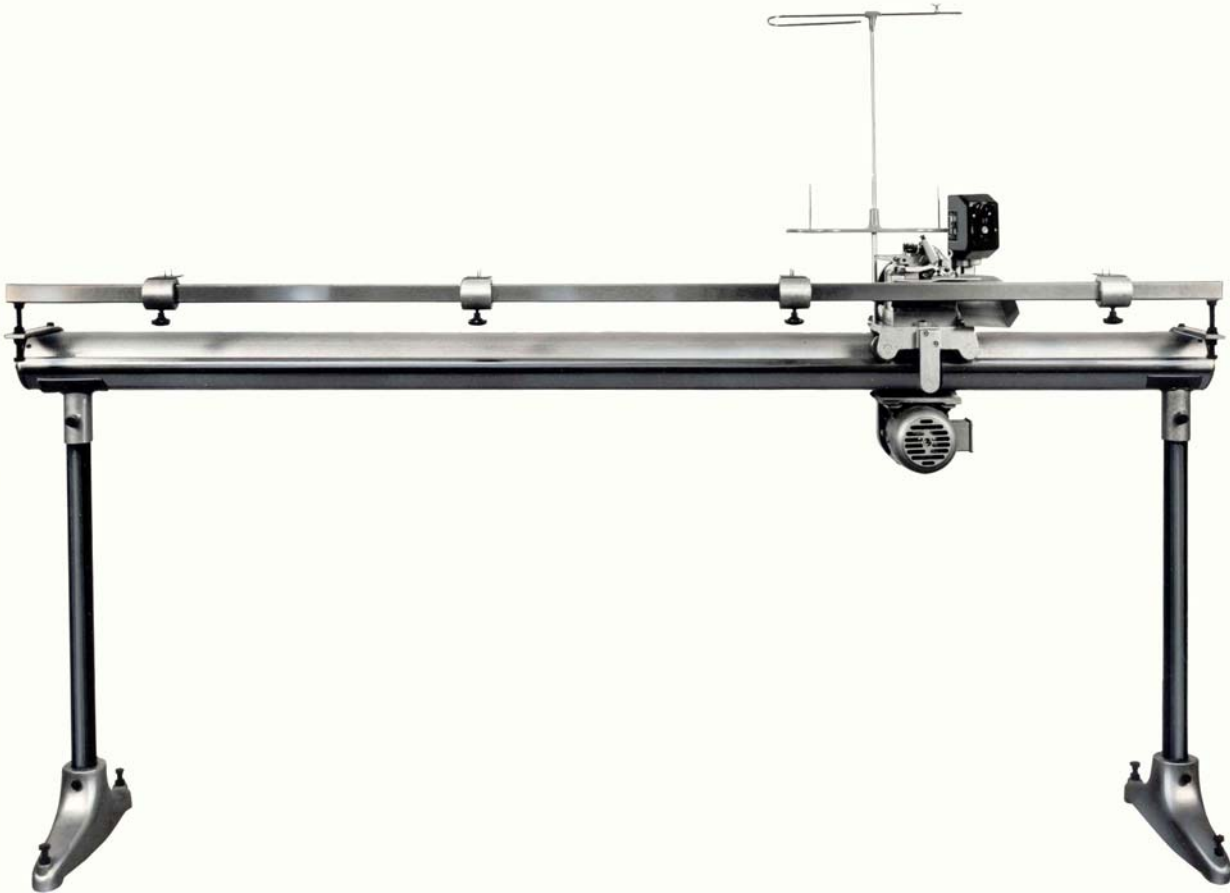

- **Perfect for the endwise joining of piece goods with a straight seam**
- **No distortion, no creases, no impression when rolling up the cloth**
- **High seam stability due to consistency of the seam**
- **Solid construction, maintenance-free**
- **Corrosion-resistant surfaces, stainless steel, aluminium, plastic surface**
- **Flexible unit construction system**

SCHWEIZER RAILWAY CARRIERS have been especially designed to meet the requirements of the textile industry in order to produce a high-quality, accurate connecting seam for the endwise joining of piece goods. After fixing one cloth on top of the other, both layers are sewn together with a precise, straight seam without creases by means of the sewing machine moving on the railway. Due to varied possibilities of application, the railway carrier can be delivered in various versions and in every length required. Both dry and wet fabric can be processed. The railway carrier can be fixed permanently on a textile machine, mounted stationary on stands or used flexible on rolls.

The material can be fixed in different ways:

1. Adjustable needle devices, for loosely woven or normal to rough textiles
2. Manual-operated clamp ledge, for fine and soft as well as elastic textiles or foils
3. Electrically driven clamp ledge, if strong fixing is required, for heavy materials

The SCHWEIZER RAILWAY CARRIER is suitable for the following MERROW machines:

70-D3B-2, 72-D3B	one-thread machine for a butted seam
70-Y3B-2, 72-Y3B	one-thread machine for a butted seam with a device for reducing the stitch length
72-D3B-R	one-thread machine for a rolled seam
70-1D-7	one-thread machine for a butted seam, fine knitwear

The SCHWEIZER RAILWAY CARRIER can be used with all types of electricity as well as ISO protection classes. You can process fabrics with a width of up to 5.000 mm stepwise. Please take measurements from the list.

## Schweizer Railway Carrier for MERROW Sewing Machines

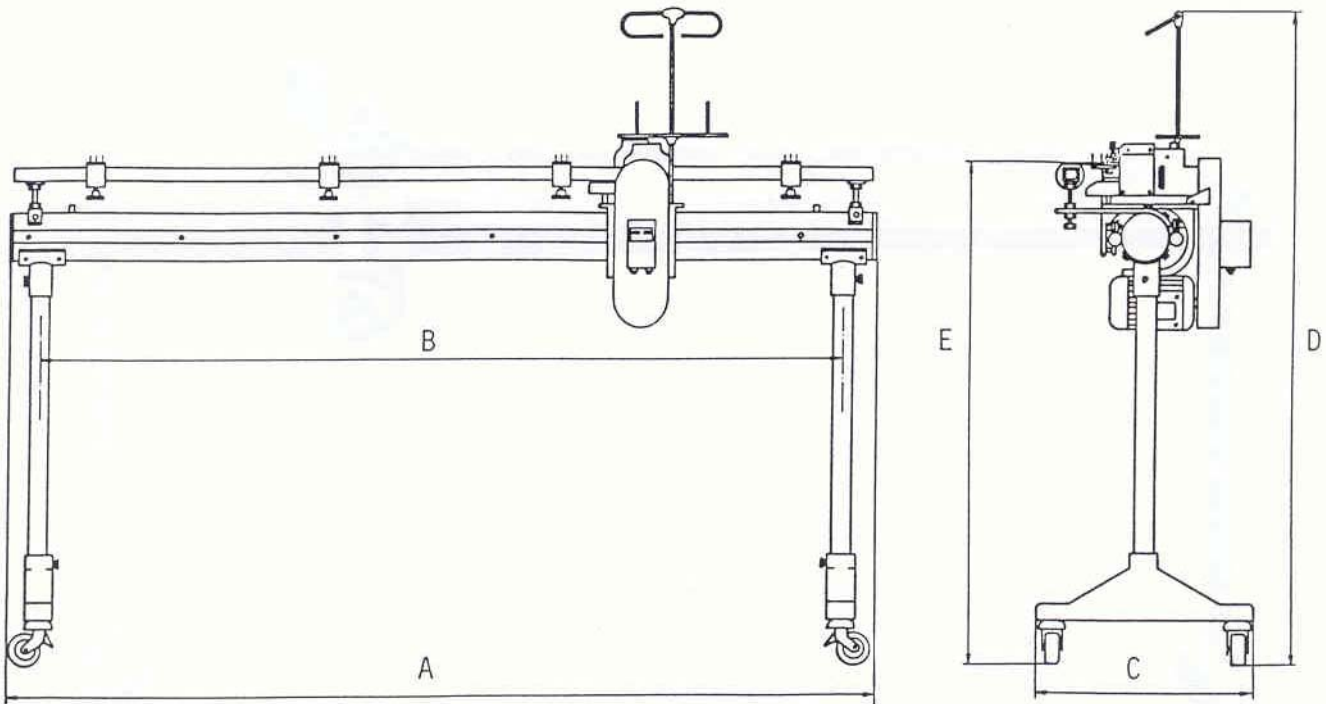

Corresponding measurements:

L (mm)	1200	1400	1600	1800	2000	2200	2400	2600	2800	3000
A (mm)	1850	2050	2250	2450	2650	2850	3050	3250	3450	3650
B (mm)	1680	1880	2080	2280	2480	2680	2880	3080	3280	3480

L (mm)	3200	3400	3600	3800	4000	4200	4400	4600	4800	5000
A (mm)	3850	4050	4250	4450	4650	4850	5050	5250	5450	5650
B (mm)	3680	3880	4080	4280	4480	4680	4880	5080	5280	5480

L = fabric width (The way the carrier can drive is the width of fabric + 100 mm)

Measurements:

C (mm)	560
D (mm)	1750 – 1850
E (mm)	1150 – 1300

Please give us the following information when asking for an offer or placing an order:

- fabric width
- flexible or stationary
- kind of material fixing
- electricity and voltage
- MERROW sewing machine class
- special requirements
- sample of fabric

## SCHWEIZER

Industrial Sewing Machines

Hochster Strasse 40  
D – 65835 Liederbach

Tel. +49-69-33996680  
Fax +49-69-33996688

Email: [info@schweizer-naemaschinen.de](mailto:info@schweizer-naemaschinen.de)  
[www.schweizer-naemaschinen.de](http://www.schweizer-naemaschinen.de)

**MERROW**  
MACHINE COMPANY  
MADE IN U.S.A. SINCE 1838